

HERCULES HOISTS LIMITED



Steel Mill Duty Wire Rope Hoist

- ◆ Lifting
- ◆ Moving
- ◆ Storing



- ▶ Extensive range
SWL 5T to 60T , Lifts upto 150 mtr.
- ▶ Heavy duty construction
Suitable for use in demanding applications
- ▶ Robust and modular design
Easy access to gear-box, motor, drum, brake and panel unit
- ▶ LH/RH (4/2 falls) grooves on drum
True vertical lifts
- ▶ Twin drum option available
High speed and high lift option readily available
- ▶ Optional VFD, radio remotes, shoe brake PLC control
Truly customized
- ▶ Hoist and electric control design available for hazardous area application
Extended application capability

Material Handling. Delivered.

Redefining Material Handling. Since 1962.

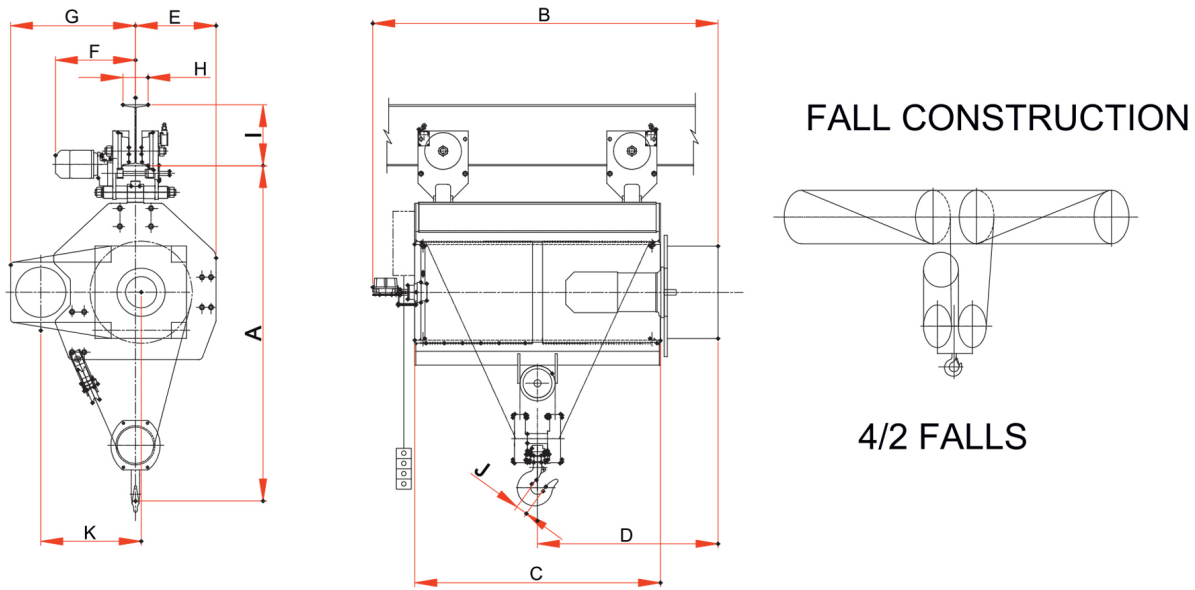

Type		SMD 5T-4/2F				SMD 10T-4/2F			SMD 15T/20T-4/2F		
		H2	H3	H5	H7	H2	H4	H6	H6	H9	H12
SWL	Tones	5				10			15/20		
Class		II				II			II		
Lift	Meter	20.0	30.0	50.0	70.0	20.0	40.0	60.0	20.0	40.0	60.0
No. Of Falls		4/2				4/2			4/2		
Rope Drum PCD	mm	509				509			610		
Wire Rope Dia.	mm	11				13			18		
Hoisting Speed	M/Min.	4.3				4.3			4.3		
Hoisting Motor	Kw/RPM	5.5/1000				9.3/1000			15.0/1500		
Travelling Speed	M/Min.	12.0				12.0			12.0		
Travelling Motor	Kw/RPM	0.37/750				0.55/750 (2 Nos.)			0.55/750 (2 Nos.)		
Trolley Wheel Dia/(Qty)	mm/(Nos)	140 (4)				140 (4)			140 (4)		
Dimn. A(Head Room)	mm	1800				1950			2300		
Dimn. B	mm	1646	1976	2907	3657	2054	2704	3504	2252	3152	4052
Dimn. C Drum Length	mm	980	1310	1970	2570	1200	1850	2650	1400	2300	3200
Dimn. D	mm	823	988	1318	1618	933	1258	1658	1033	1483	1933
Dimn. E	mm	500				700			700		
Dimn. F	mm	675				500-600			500-600		
Dimn. G	mm	800				685			775		
Dimn. H Beam Flange	mm	125-210				125-210			125-210		
Dimn. I Beam	mm	250				450			450		
Dimn. J	mm	53				78			95		
Dimn. K	mm	400				554			600		
Weight	Kg.	650	700	750	800	950	1075	1150	1150	1250	1400

NOTES:

- 1) TROLLEY SPEED 3.5, 7, 12, 26 mpm OPTIONAL AT EXTRA COST.
- 2) SHOE BRAKE CAN BE SUPPLIED FOR HOISTING MOTION AT EXTRA COST.

Data Tolerance ±10% .

HERCULES HOISTS LIMITED

AUTHORISED BUSINESS PARTNER

ELEQUIP TOOLS PVT. LTD.

19 Pollock Street 2nd Floor Kolkata 700 001 WB

Tel : +91 (033) 22351792/2400 | M: 9674322200

www.ehoists.in | contact@ehoists.in

Regional Sales & Service Office:

Delhi, Kolkata, Chennai, Pune
Works

Khalapur, Pune

