

HERCULES HOISTS LIMITED



iR Series

Wire Rope Hoists

- ◆ Lifting
- ◆ Moving
- ◆ Storing



Material Handling. Delivered

Redefining Material Handling. Since 1962.

Why Indef iR Hoist?

1. **World Class Hoist:** Optimized design complying with international FEM Norms
 - Indef iR hoists have been designed in conformity with FEM classification 2m
 - The gearbox service life is rated for more than 2000 hours at full load.
2. **Compact Modular Design**
 - The Indef iR rope hoist provides better side approaches enabling better utilization of the shed space
 - With a modular design, maintenance is simplified enabling quick maintenance to enable high uptime of the hoist.
3. **High Performance Gearbox**
 - Compact, low maintenance, low noise, multistage, lube immersed gearbox directly coupled to rope drum for high efficiency
 - Hardened and ground gears for long life, low noise, highly durable gearing.
4. **Economical In Operation**
 - Optimised motor capacities for efficient power consumption
5. **Efficient Motor**
 - Light weight, robust die-cast aluminium alloy gearbox body for lower deadweight
 - Directly coupled three stage shaft mounted drive directly connected to rope drum.
6. **Efficient Motor**
 - Efficiently designed, green technology IP 55 enclosure based, optimised motor design for low noise and low vibration operation
 - Provision for thermocouple and encoder adaptation if demanded by application.
7. **Flexible Design**
 - Design adaptable to meet customer specific requirements for components (motors, VFD, brake, wire-rope etc.)
 - Optional of dual speed upgrade kit .
8. **Fast Acting Brake**
 - Fast action electromagnetic disc brakes for enhanced safety.
 - Factor of safety of 1.5
9. **Single Speed / Dual Speed Options**
 - Single speed standard
 - Dual Speed with frequency inverter on request allowing frequency range from 10% minimum to 100%
 - Dual speed upgrade kit can be provided.

Hoist Model	Capacity ton	Design Duty Class FEM	Reeving No. of Falls	Lifting Speed MPM	Hoist Motor kW	Head Room mm	Rope Dia. mm	Monorail Beam		Cross Travel		
								Width Range mm	Thickness mm	Kw KW x number of motor	MPM	Wheel Dia mm
IR-010-21-BT	1	2 m	2	6	1.3	1050	8	90-180	20	0.37 x 1	17	140
IR-020-41-BT	2	2 m	4	3	1.3	1050	8	90-180	20	0.37 x 1	17	140
IR-016-21-BT	1.6	2 m	2	7	2.5	1050	8	90-180	20	0.37 x 1	17	140
IR-032-41-BT	3.2	2 m	4	3.5	2.5	1050	8	150-210	20	0.37 x 1	17	140
IR-020-21-BT	2	2 m	2	6	2.5	1050	10	90-180	20	0.37 x 1	17	140
IR-040-41-BT	4	2 m	4	3	2.5	1050	10	90-180	20	0.37 x 1	17	140
IR-025-21-BT	2.5	2 m	2	8	4.1	1250	10	125-210	20	0.37 x 1	17	140
IR-050-41-BT	5	2 m	4	4	4.1	1250	10	125-210	20	0.37 x 1	17	140
IR-050-21-BT	5	2 m	2	8	8.1	1550	13	125-210	20	0.37 x 1	17	140
IR-100-41-BT	10	2 m	4	4	8.1	1550	13	125-210	25	0.37 x 2	17	160
IR-063-21-BT	6.3	2 m	2	8	10.5	1600	13	125-210	20	0.37 x 1	17	140
IR-125-41-BT	12.5	2 m	4	4	10.5	1600	13	125-210	20	0.55 x 2	17	160
IR-075-21-BT	7.5	2 m	2	7	10.5	2000	16	125-210	25	0.37 x 2	17	160
IR-150-41-BT	15	2 m	4	3.5	10.5	2000	16	125-210	25	0.55 x 2	17	140
IR-100-21-BT	10	2 m	2	7	14	2000	16	125-210	25	0.37 x 2	17	160
IR-200-41-BT	20	2 m	4	3.5	14	2000	16	125-210	25	0.55 x 2	17	140

Note

- Above dimensions are applicable for single speed hoisting/lowering & cross travel motions only.
- All dimensions are in mm
- All dimensions are with in $\pm 5\%$ of specified dimensions

9 **Protective Rope Guide**

- Built with special engineering grade thermoplastic with high wear and heat resistance
- Reduced wire rope wear

10 **Overload Protection As Standard**

- Overload protection integrated in the hoist for user and asset safety.

11 **One Hoist, Many Avatars**

- Bogie / Fixed Trolley or Low Headroom or Foot mounted or Crab mounted execution
- Standard Execution or EX/FLP Execution
- Standard Lift (2/1 or 4/1 reeving) or True Lift (4/2reeving)
- From 1t to 20t SWL.

12 **Proven Technology From A Trusted Brand**

- More than 4 decades of experience in designing, manufacturing and supporting electrical hoists covering more than 2,00,000 units.

13 **Indef Sales And Service Within Immediate Reach**

- Accessible sales and service support from more than 50 Authorised Business Partners providing stock, sale and service facilities and more than 100 authorised retailers all over India

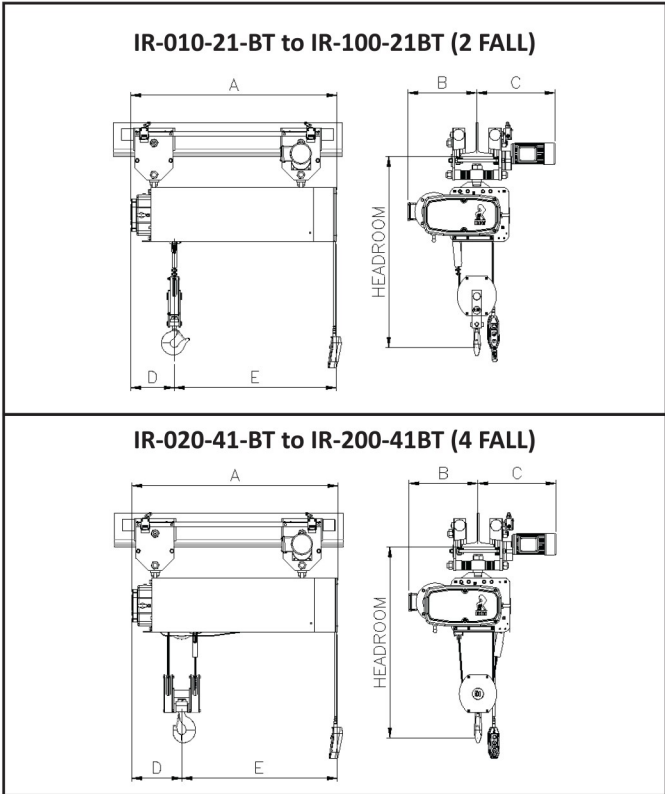

Typical GA Dimensions

No of wheels	Lift 6 m(4 fall) / Lift 12m (2 fall)					Lift 9 m(4 fall) / Lift 18m (2 fall)					Lift 12 m(4 fall) / Lift 24m (2 fall)				
	A	B	C	D	E	A	B	C	D	E	A	B	C	D	E
4	1105	390	465-510	290	815	1395	390	465-510	290	1105	1695	390	465-510	290	1405
4	1105	390	465-510	290	815	1395	390	465-510	290	1105	1695	390	465-510	290	1405
4	1165	390	465-510	300	865	1295	390	465-510	300	995	1556	390	465-510	300	1256
4	1165	390	475-520	320	845	1295	390	475-520	320	975	1556	390	475-520	320	1236
4	1105	390	465-510	300	805	1395	390	465-510	300	1095	1695	390	465-510	300	1395
4	1105	390	475-520	320	785	1395	390	475-520	320	1075	1695	390	475-520	320	1375
4	1075	460	525-570	310	765	1305	460	525-570	310	995	1565	460	525-570	310	1255
4	1075	460	525-570	350	1020	1305	460	525-570	350	955	1565	460	525-570	350	1215
4	1320	550	535-580	440	1020	1530	550	535-580	440	1090	1740	550	535-580	440	1300
4	1320	550	535-580	550	1020	1530	550	535-580	550	980	1740	550	535-580	550	1190
4	1320	550	535-580	440	1020	1530	550	535-580	440	1090	1740	550	535-580	440	1300
4	1320	550	535-580	550	1020	1530	550	535-580	550	980	1740	550	535-580	550	1190
4	1330	600	535-580	500	1020	1530	600	535-580	500	1030	1740	600	535-580	500	1240
8	1330	600	535-550	550	1020	1530	600	535-550	550	980	1740	600	535-550	550	1190
4	1330	600	535-580	500	1020	1530	600	535-580	500	1030	1740	600	535-580	500	1240
8	1330	600	535-550	550	1020	1530	600	535-550	550	980	1740	600	535-550	550	1190

- Actual hoisting/lowering & cross travel speed is within ± 10% of specified speed
- Hoist with inverter speed are also available in above range.
- Due to continuous development and improvement specifications listed above can change without notice.

PRODUCTIVITY - RELIABILITY - SAFETY

For more than five decades now, Indef hoisting products are the Indian industry's "go to" solution for any material handling requirement.

Our products are known for their enduring design and build that ensures cost effective, reliable productivity and safety to our customers.

This is simply the reason that Indef hoists are the market leaders in India. Big and small - our customer base spans almost all industrial sectors: name a sector and we can name many customers in that sector, most of them the leading names.

Our newly designed and developed Indef iR Series wire rope hoists are not only optimised for standalone hoisting but also crane applications, meeting the needs of users across a wide spectrum of customers.

The innovatively designed iR rope hoist satisfies all the needs of the market for reliable productivity, efficiency and safety, easily justifying the investment for organisations and their users.

Our integrated design and manufacturing facility is equipped with contemporary production and testing facilities and has its quality systems certified to ISO 9001:2015 standards. Using state-of-the-art design methodologies, our team of engineers design robust products and solutions to support the most demanding material handling requirements.

No wonder, our brand Indef is synonymous with customer requirements for **LIFTING, MOVING and STORING**.

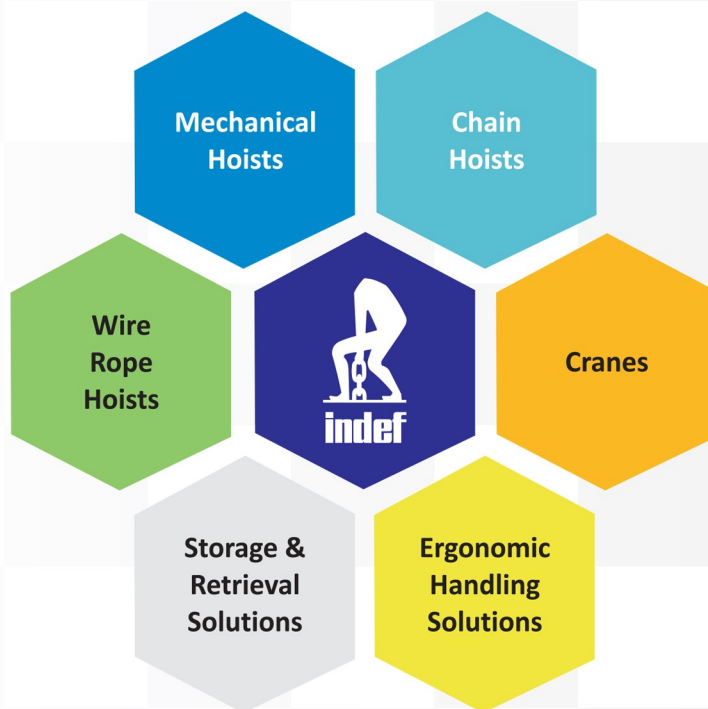

HERCULES HOISTS LIMITED

AUTHORISED BUSINESS PARTNER

ELEQUIP TOOLS PVT. LTD.

19 Pollock Street 2nd Floor Kolkata 700 001 WB

Tel : +91 (033) 22351792/2400 | M: 9674322200

www.ehoists.in | contact@ehoists.in

Regional Offices :

Mumbai, Delhi, Kolkatta , Chennai, Pune

www.indef.com